

Happy Gudi Padwa



CEEAMA E-NEWS

Published by Consulting Electrical Engineers Association of Maharashtra

For Free Private Circulation only

Volume 2 Issue# 3

Electrical Consultants' Newsletter

March 2018

From the Secretary's Desk



Dear All,

First of all, I wish all of you a very happy and prosperous new year!!

In the year 2004 on Gudhipadva foundation of CEEAMA is laid. In last 14 years CEEAMA had made its route stronger

and started growing. Let's come together and make the new year very successful for CEEAMA.

To reach every member we need to have latest details of each member. Further to help each other we also need some professional details of everyone. With this aim, we had requested all the members to update their profile in specific format. It is observed that many of our member have not updated their profile on our CEEAMA website, www.ceeama.org

We once again appeal all the members to enter / update their profile. This will help the person, member or probable customer to find out the electrical consultant of his choice. All future communications & program aimed at particular consultant segment will be directed to those who have updated the profile on the website.

Lot many things are happening and CEEAMA intends to increase the participation of the member to achieve the final goal.

This year CEEAMA will conduct 4 programs each at Mumbai and Pune. Details of the same shall be circulated to all shortly.

In Pune, program will be conducted from April 2018. First Program is scheduled on 13th April 2018. Details of the same shall be circulated shortly.

I m looking forward for specific suggestions on how CEEAMA can help to achieve the solar power grid target of 100 gigawatt as declared by our Hon. Prime Minister.

I request all of you to visit our website regularly. Send your suggestion ideas to me for discussion & implementation. My Email ID is suhas.keskar@ceeama.org.

Thanking you all once again.

Best Regards,
Suhas Keskar
Hon. Secretary

In This Issue...

What is New?

Bladeless Wind Turbine

Technical Notes

Damages due to Neutral failure in 3 phase connections feeding mostly single phase loads

Article

Turbulent Mini Hydro Power

Energy Conservation Building Code (ECBC)

What is New?

Bladeless Wind Turbine

The wind turbines we currently use for wind power are incredibly advanced pieces of technology. Everything inside of them –from the shape of their airfoils to the generators they spin– has been painstakingly engineered for maximum efficiency.

These incredible tube-like wind turbines from Spanish startup Vortex Bladeless. Through a clever manipulation of physics, the company's turbines are able to generate electricity without the help of any large, spinning blades.

Instead of capturing energy through the circular motion of a propeller, Vortex turbines take advantage of a physical phenomenon known as vorticity — an aerodynamic effect that creates a pattern of spinning vortices or whirlwinds.

As the wind blows past the turbine, little whirlwinds are created behind it, and when they get big enough, they cause the structure to oscillate. This kinetic energy is then used to power an alternator, which multiplies the frequency of the tower's oscillation and converts the motion in to usable electricity.

The result? A drastically cheaper wind turbine. Vortex claims that its design can reduce manufacturing costs by 53%, cut maintenance costs by 80%, and would represent a 40% reduction in both the carbon footprint and generation costs when compared to conventional bladed wind turbines. They're also quieter and present a much lower risk to birds who fly near them.



These bladeless wind turbines create electricity without spinning. Instead of capturing energy through the circular motion of a propeller, Vortex turbines take advantage of a physical phenomenon known as vorticity -- an aerodynamic effect that creates a pattern of spinning vortices or whirlwinds.

By **Mangesh Shirgaonkar**

Article

TURBULENT MINI HYDRO POWER

POWER RANGE OF THE VORTEX TURBINE

- **Nominal Power** : 5 to 100 kW depending on head and flow
- **Nominal Head** : From 1,5m and above
- **Nominal Flow** : From 1000 l/s and above,

THE TURBINE

Imagine you could use any kind of small head difference in a river or canal. The power those drops contain might surprise you. We created a technology that can make use of all these small waterfalls or rapids in a way that's safe for the environment. Gone are the days that communities had to choose between having power or fish to eat. Our robust and fish friendly vortex turbines will generate energy 24/7 at an incredibly low cost of energy. That way you can have a project with high return on investment that improves the world just that little bit.

Now, if you look at a river or canal, you'll notice that it's full of these small cascades, that's how nature builds rivers. We have created a distributed turbine system that can combine a large amount of turbines into one big virtual hydropower power plant. These virtual hydropower plants can be as large as 10MW in power output. That's the power production of a small city! We can do this because our civil structures are designed to be easy to install, and the electronics and robust power take-offs are designed to keep working with minimal maintenance.

The energy produced can be directly connected to your appliances or machinery, and at the same time connected to the national distribution grid, so you can inject the unused power to it, maximizing the revenue through a net billing connection.

MECHANICAL SPECIFICATIONS

- Dry weight: 700kg (excluding the basin)
- Height: 1.5m – 3m with a cascade of turbines for larger heads
- CFD optimized basin with a diameter of 3.8m up to 6m for 100kW
- Concrete basin, designed for a life of 100 years
- Fiber-composite impeller with impact-proof coating
- Self-cleaning trash rack for larger debris (> 25cm)
- Flow control and automatic actuated sluice gate

ELECTRIC SYSTEM

- Suited for 220-480v and 50/60Hz
- Single phase (<5 kW) – Three phase (> 5kW)
- IP68 Waterproof generator with double barrier mechanical ace seal system
- Active rectifier and inverter with diversion load to improve stability
- Off-grid systems

HOW DOES IT WORK?

The operation of the turbine is quite simple. It has only one moving part, extending its operating life, energy production and thus requiring very little maintenance

- A self-cleaning screen holds large debris out of the turbine
- The flow is guided into a vortex through our optimized concrete basin.
- The vortex turns a specially designed impeller.
- The water flows back into the stream with all debris gone through and all fish unharmed

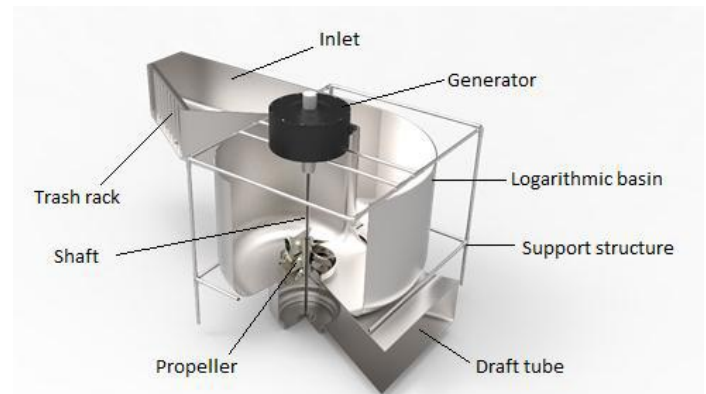

Contributed by: A V Prasanna



Article 2

Energy Conservation Building Code (ECBC)

Preamble:

Energy production and consumption using fossil fuels is now recognized as the largest contributor to human induced greenhouse gas emission, held responsible for global climate change. Buildings contribute nearly 30% of annual greenhouse gas emissions and consume 30% of energy worldwide. In a developing country, such as India, which is urbanizing at a rapid pace, the consumption of energy by buildings is projected to grow at 8% a year. It has been estimated that, nearly 67% of new commercial floor space across the country is projected to be constructed by 2030.

In order to deal with the challenge of growth and the need to reduce energy consumption, the Energy Conservation Act 2001, enacted by the Government of India, established the Bureau of Energy Efficiency (BEE) under Ministry of Power, to develop policies and implement techniques related to energy efficiency across all sectors. **The Energy Conservation Building Code (ECBC) 2007** launched by BEE, prescribes minimum standards to achieve energy efficiency in buildings. It is projected that ECBC has the potential to reduce average energy consumption by 30–40% in new commercial buildings and can achieve an annual energy saving of 1.7 billion kWh.

In the “**National Mission on Sustainable Habitat**” under National Action Plan for Climate Change, announced by the Prime Minister; the building sector has been identified as one of the key sectors. The 12th five year plan (April 2012 – March 2017) recognizes energy conservation measures as a key to demand side management.

Building Envelope	Heating Ventilation & Air Conditioning	Water Heating & Pumping	Lighting	Electrical Power
Insulation Materials	Efficient HVAC System	Solar Water Heating	Efficient Light Bulbs (CFL, LED)	Motor Efficiency
Fenestration (windows, natural light)	Duct Sealing (avoid air leaks)	Equipment Efficiency	Automatic Lighting Shut-off	Transformer Efficiency
Envelope Sealing (avoid leakage)	Natural Ventilation	Piping Insulation	Occupancy Sensors (turn off when no movement)	Electric Metering and Monitoring
Cool Roofs (reflective/ white roof)	System Balancing (fans adjust airflow)	Heat Traps (pipe valves to prevent hot water loss)	Master Lighting Controls	Power Distribution Systems

Source: BEE and USAID ECO-III, Energy Conservation Building Code User Guide, July 2009, <http://www.beeindia.in/>.

Commercial Sector:

Commercial buildings include offices, hospitals, hotels, retail outlets, educational buildings, government offices. Energy consumption in buildings offers a large scope for improving efficiency. The major energy-consuming equipments in the commercial sector are HVAC (59%), lighting (32%), and other office related equipment (9%).

The residential and commercial buildings account for 29% of the total electricity consumption and this is rising at a rate of 8% per annum. The major growth in constructed area up to 2030 will be seen by residential and commercial sectors, as much as 4 to 5 times the constructed area in 2005. The commercial built up area is projected to increase from 2,900 million ft² in 2005 to 20,000 million ft² by 2030.

The need for office space is rising and around 5.50 million m² of office space has been added annually, in the top seven Indian cities, with total office floor space rising to more than 28 million m². Given this growth, ensuring that each new building development is energy efficient must become a top priority.

The Central Electricity Authority estimates that India experiences a shortage of 9.9% and peak demand shortage of 16.6%.

In the year 2017, revised set of ECBC (**ECBC-2017**) has been introduced and it has 3-tiers of commercial buildings, viz., **ECBC compliant buildings**, which are 30% better than typical commercial buildings. **ECBC+ buildings**, which are 20% better than ECBC compliant buildings and **SuperECBC buildings**, which are 50% better than ECBC compliant buildings.

Implementation of ECBC in Maharashtra:

Maharashtra is the largest electricity consuming state in India. It is also one of the most urbanized states with the largest urban population in the country. Of the total installed capacity of 26,538 MW as on 31st July 2012 (amounting to 12.85% of the total installed capacity in India), it presently sources nearly 5000 MW from outside the state, while another 4000 MW of power is being scheduled to be added to the transmission network by 2013.

Of the total installed capacity, nearly 70% is attributed to coal-based sources which add to its carbon emissions load. The need to control greenhouse gas emissions through energy conservation measures such as ECBC; is very relevant for the state of Maharashtra.

ECBC guidelines are applicable to buildings having connected load of above 100 kW or contract demand of minimum 120 KVA or air conditioned floor area of 1000 m² or more.

ECBC has categorized the country on the basis of climate and five climatic zones. It includes a set of requirements for building energy performance including building envelope, lighting, electrical and HVAC systems. Mandatory thermal properties for building envelope (Roof, Walls and Windows) were developed based on the climate. The ECBC requirements are in tandem with Indian vernacular architecture where buildings were constructed in response to local climate.

In series of articles, in the coming months, we shall cover various aspects of ECBC requirements, such as Envelope (Walls, Roof and Windows), Air Conditioning Systems and Controls, Lighting and Da-lighting, Service Hot Water and Electrical Systems.

By Shirish Deshpande

Source: BEE & USAID ECO-III, Energy Conservation Building Code User Guide, July 2009, www.beeindia.in

Technical note

Subject: Damages due to Neutral failure in 3 phase connections feeding mostly single phase loads.

During the course of power quality audits to locate cause of frequent equipment failures, especially in case of **small or medium hospitals and banks**, it is observed that in most of the cases the cause is NEUTRAL DISCONNECTION.

Small hospitals / Nursing homes / Small Branches of various banks etc have sanctioned electrical loads which are less than 50KW and become LT consumers of utility company. Such connections work on a 4 wire R-Y-B-N connection available from MSEDCL. **Usually these applications being critical, they are supported with back up DG sets which also are 4 wire systems. Most of the loads here are single phase costly or critical equipments like computers with important data, medical equipment etc.**

Such establishments usually depend on "Contracted Electrician" who does repairs and attends to breakdowns. Such a person is usually capable of undertaking front line liaison with concerned utility company although in most of the cases he is not qualified to do the job. Usually management of such establishments is "Electrically illiterate" and depends fully on such person. The management tends to avoid involvement of electrical consultant in view of cost cutting.

Our Observations:

- 1) As per present norms, MSEDCL insists on an arrangement – auto or manual – which will keep only one neutral connected to the circuit, the one provided by utility or other provided by DG sets. These changeover circuits are not maintained properly and result into neutral disconnection due to loose contact or a faulty contactor in AMF switch etc.
- 2) LT 3 phase connection is usually given by tapping all four wires from the nearby pole without taking proper precaution while preparing the joint. Most of such joints carry huge harmonic currents as most of the LT loads are non linear.
- 3) Such single phase circuits are usually tapped internally when a new load is added, without considering capacities of incoming conductor.

All these negligence and so called cost saving causes tremendous problems on a particular day and results into huge loss. We have seen hospitals postponing open heart surgeries due to this and banks not able to offer services to clients or 2 / 3 days till the fire

fighting on the front of repairs is over. Neutral failure for single phase loads results into unbalanced high voltages and can result into fire due to insulation failure in electrical equipment.

With all this fact remains that such clients still avail our services after major disaster and not as preventive or predictive major; Whereas we are offering our services to multinational banks twice a year on contract basis.

Our recommendation to clients:

As dependency on utility company workmanship cannot be guaranteed, we recommend our clients to install isolation transformers at the input with DELTA primary and STAR secondary configuration and create own neutral by grounding star point of this transformer. This transformer should be simple double wound power transformer with voltage ratio as 1:1. The rating should be decided based on load profile and current harmonic contents. There is no need of Ultra isolation etc which would increase cost.

If voltage profile on 24 hours is fairly acceptable, then there is no need of servo stabilizer after this.

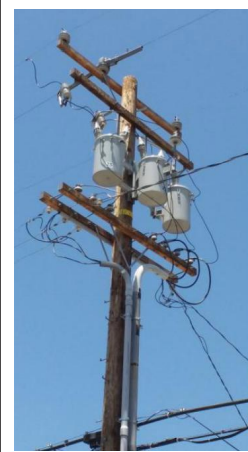

I am enclosing a photograph of distribution around overhead conductors from USA. This was shot during my recent visit. It appears that a sincere hard work definitely follows behind the "Electric Supply Reliability" which they boast off.

In view of reducing distribution loss at 110V level (as currents are higher), they use pole mounted transformers for all LT or single phase loads. One can see method of connections and neatness followed in workmanship. All tap offs use connectors.

Can our clients expect this any time in future? Will our clients act in proactive way?

All AMF / Auto change over arrangements should be serviced properly. The isolation transformer as above should be installed after the change over arrangement so that the load is always protected.

Utility companies should provide proper joints for tap offs.

Prepared by

Narendra Duvedi

Announcing...

CEEAMATECH-2019

7th Exhibition & Conference on Electrical Industry

8th to 10th February 2019

Auto Cluster, Chinchwad, Pune



Mark your Diary

13th April 2018: Technical Seminar Programme on Diesel Engines and Generating sets

Venue: Pune, Venue to be confirmed soon.

19th -21st April 2018 : World build India B2B Exhibition for the Construction Industry.

Venue: Hall 1, Bombay Exhibition Centre, Mumbai.

India's most relevant B2B Exhibition
for the **Construction Industry**



Location
**Bombay
Exhibition Center,
Mumbai, India**

Dates
19 – 21 April 2018

2017 Event Statistics

33,450+ Visitors

220+ Exhibitors

25 Participating Countries

80+ Event Speakers



Ar. Jan Gehl

Visitor Statistics

78% visitors made purchase

89% visitors were decision makers / influencers

70% visitors sourced new suppliers

62% visitors don't attend other Exhibitions

Conferences | Competitions | Seminars | Awards

Philips Liveable City

- Icon Lecture
- Keynote Address
- Panel Discussions
- 350 Plus Delegates

Engineering for state-of-the-art built environment

- In Association with CEAI
- 10 Speakers
- 200 plus delegates

Builders Association of India Conclave

- 150 delegates

Nerolac Breathing City

- 180 participants
- Ideas generated for 10 Indian Cities

Innovations in Structural Design & Construction

- Climatic Session
- 300 plus delegates
- 13 Speakers

PCERF Safety & Vidayarthee Awards

- 400 plus nominations
- 400 plus attendees

Vision India Pavilion

- 2 Municipal Corporations
- 10 Architecture studio's
- 1 Engineering Company

BOOK YOUR SPACE 2018

Key Participants 2018



Melanie Carvalho: +91 97734 56576 | Devang Gadani : +91 88988 08013



Website: www.worldbuild-india.com | Email: sales@worldbuildindia.com

